

# FYC 30 TF

Housing material

Cast iron

## Dimensions

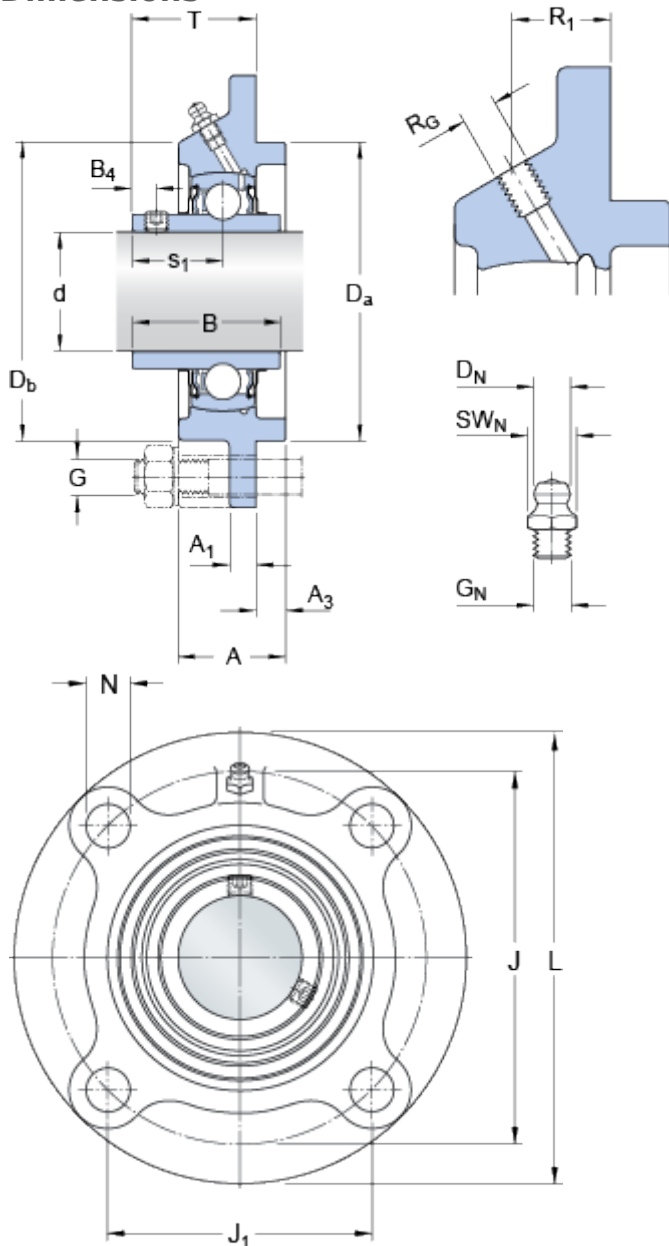

d	30	mm
A	31	mm
A <sub>1</sub>	8	mm
A <sub>3</sub>	8	mm
B	38.1	mm
B <sub>4</sub>	5	mm
D <sub>a</sub>	h8 80	mm
D <sub>b</sub>	81.1	mm
J	100	mm
J <sub>1</sub>	70.7	mm
L	125	mm
N	12	mm
s <sub>1</sub>	22.2	mm
T	32.2	mm

## Threaded hole

R<sub>G</sub> 1/4-28 UNF

R<sub>1</sub> 16.5 mm

## Grease fitting

D<sub>N</sub> 6.5 mm

SW<sub>N</sub> 7 mm

G<sub>N</sub> 1/4-28 SAE-LT

## Calculation data

Basic dynamic load rating	C	19.5	kN
Basic static load rating	C	11.2	kN
Fatigue load limit	P <sub>u</sub>	0.475	kN
Limiting speed with shaft tolerance h6		6300	r/min

## Mass

Mass unit	1.25	kg
-----------	------	----

## Mounting information

Thread grub screw	G <sub>2</sub>	M6x0.75
Hexagonal key size for grub screw	N	3 mm
Recommended tightening torque for grub screw		4 N·m

Recommended diameter for attachment bolts, mm	G	10	mm
Recommended diameter for attachment bolts, inch	G	0.375	in

### **Appertaining products**

---

Bearing	YAR 206-2F
Housing	FYC 506