

# BA 9

## Dimensions

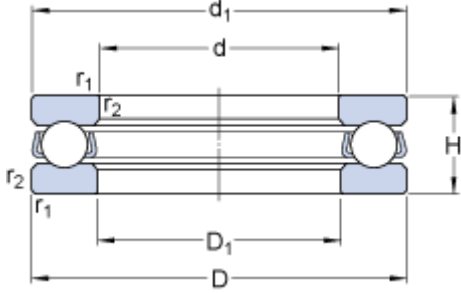

d	9	mm
D	20	mm
H	7	mm
d <sub>1</sub>	≈ 19.8	mm
D <sub>1</sub>	≈ 9.2	mm
r <sub>1,2</sub>	min. 0.3	mm

## Abutment dimensions

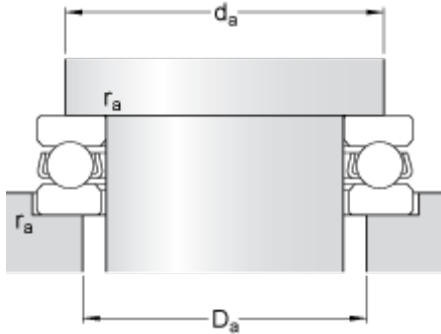

d <sub>a</sub>	min.	15.5	mm
D <sub>a</sub>	max.	13.5	mm
r <sub>a</sub>	max.	0.3	mm

## Calculation data

Basic dynamic load rating	C	3.12	kN
Basic static load rating	C	3.8	kN
Fatigue load limit	P <sub>u</sub>	0.143	kN
Reference speed		12000	r/min
Limiting speed		16000	r/min
Minimum load factor	A	0.000075	

## Mass

Mass bearing (including seat washer where applicable)	0.01	kg
---	------	----