

6309-2ZNR

SKF Explorer

Dimensions

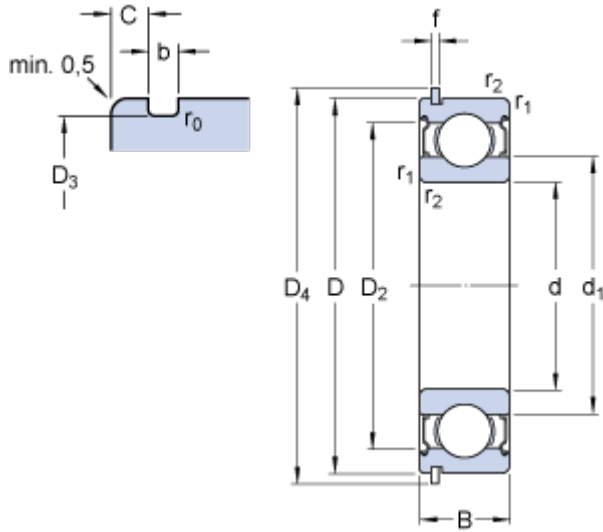

d		45	mm
D		100	mm
B		25	mm
d ₁	≈	62.18	mm
D ₂	≈	86.7	mm
D ₃		96.8	mm
D ₄		106.5	mm
b		2.7	mm
C		3.28	mm
f		2.46	mm
r	max.	0.6	mm
r _{1,2}	min.	1.5	mm

Abutment dimensions

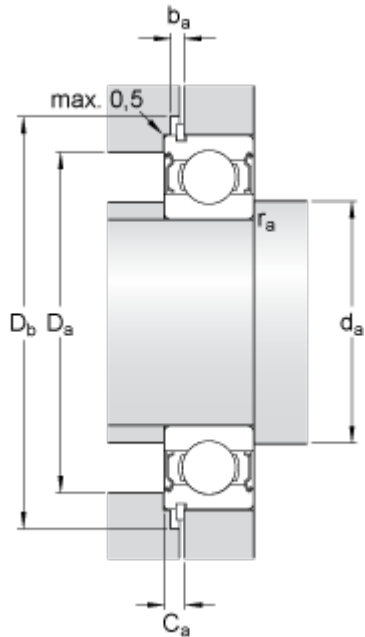

d _a	min.	54	mm
d _a	max.	62.1	mm
D _a	max.	91	mm
D _b	min.	108	mm
b _a	min.	3	mm
C _a	max.	5.74	mm
r _a	max.	1.5	mm

Calculation data

Basic dynamic load rating	C	55.3	kN
Basic static load rating	C	31.5	kN
Fatigue load limit	P _u	1.34	kN
Reference speed		15000	r/min
Limiting speed		7500	r/min
Calculation factor	k _r	0.03	
Calculation factor	f	13	

Mass

Mass bearing		0.89	kg
--------------	--	------	----

Included products

Snap ring

SP 100