

# 6201-2ZNR

SKF Explorer

## Dimensions

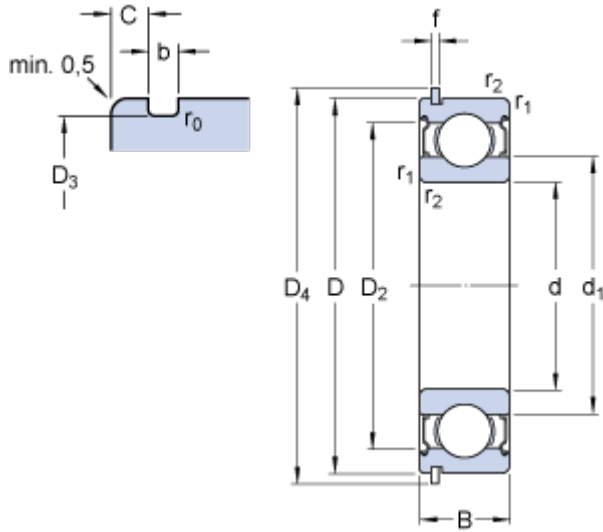

d		12	mm
D		32	mm
B		10	mm
d <sub>1</sub>	≈	18.45	mm
D <sub>2</sub>	≈	27.34	mm
D <sub>3</sub>		30.15	mm
D <sub>4</sub>		36.7	mm
b		1.35	mm
C		2.06	mm
f		1.12	mm
r	max.	0.4	mm
r <sub>1,2</sub>	min.	0.6	mm

## Abutment dimensions

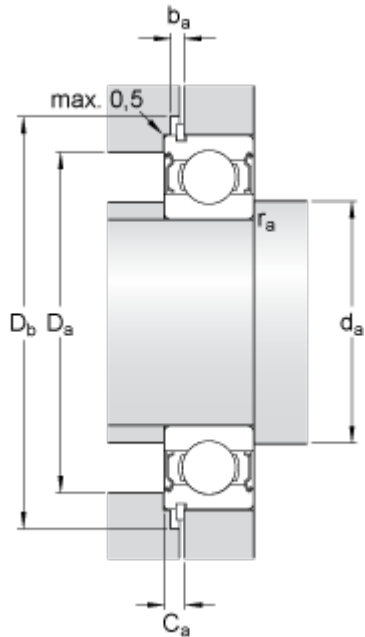

d <sub>a</sub>	min.	16.2	mm
d <sub>a</sub>	max.	18.4	mm
D <sub>a</sub>	max.	27.8	mm
D <sub>b</sub>	min.	38	mm
b <sub>a</sub>	min.	1.5	mm
C <sub>a</sub>	max.	3.18	mm
r <sub>a</sub>	max.	0.6	mm

## Calculation data

Basic dynamic load rating	C	7.28	kN
Basic static load rating	C	3.1	kN
Fatigue load limit	P <sub>u</sub>	0.132	kN
Reference speed		50000	r/min
Limiting speed		26000	r/min
Calculation factor	k <sub>r</sub>	0.025	
Calculation factor	f	12	

## Mass

Mass bearing		0.037	kg
--------------	--	-------	----

**Included products**

---

Snap ring

SP 32