

61820

Dimensions

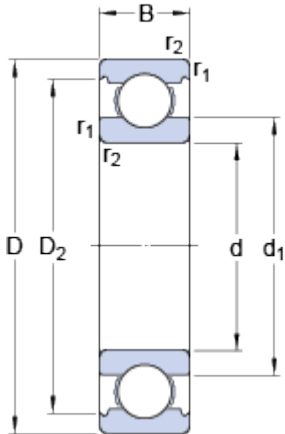

d		100	mm
D		125	mm
B		13	mm
d ₁	≈	108.3	mm
D ₂	≈	119.3	mm
r _{1,2}	min.	1	mm

Abutment dimensions

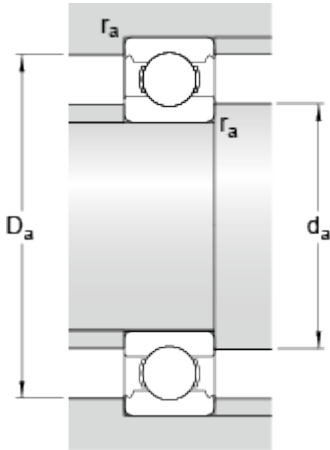

d _a	min.	105	mm
D _a	max.	120	mm
r _a	max.	1	mm

Calculation data

Basic dynamic load rating	C	17.8	kN
Basic static load rating	C	18.3	kN
Fatigue load limit	P _u	0.95	kN
Reference speed		10000	r/min
Limiting speed		6300	r/min
Calculation factor	k _r	0.015	
Calculation factor	f	13.3	

Mass

Mass bearing		0.3	kg
--------------	--	-----	----