

# 51218

## Dimensions

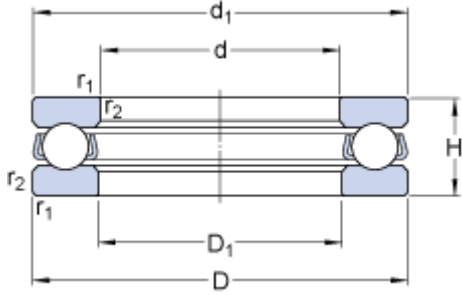

d	90	mm
D	135	mm
H	35	mm
d <sub>1</sub>	≈ 135	mm
D <sub>1</sub>	≈ 93	mm
r <sub>1,2</sub>	min. 1.1	mm

## Abutment dimensions

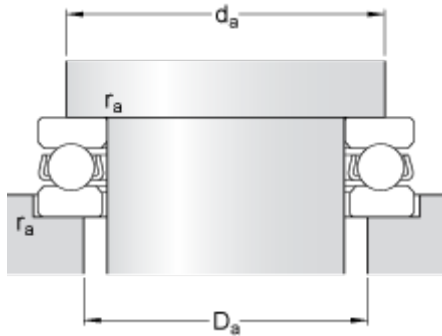

d <sub>a</sub>	min.	117	mm
D <sub>a</sub>	max.	108	mm
r <sub>a</sub>	max.	1	mm

## Calculation data

Basic dynamic load rating	C	112	kN
Basic static load rating	C	290	kN
Fatigue load limit	P <sub>u</sub>	10.4	kN
Reference speed		2000	r/min
Limiting speed		2800	r/min
Minimum load factor	A	0.55	

## Mass

Mass bearing (including seat washer where applicable)	1.7	kg
---	-----	----