

# 51216

## Dimensions

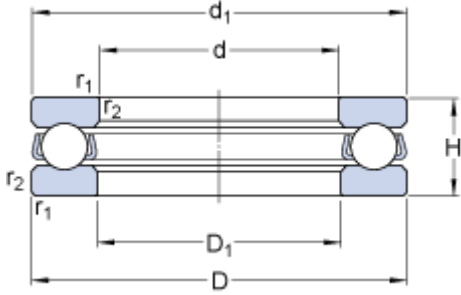

d		80	mm
D		115	mm
H		28	mm
d <sub>1</sub>	≈	115	mm
D <sub>1</sub>	≈	82	mm
r <sub>1,2</sub>	min.	1	mm

## Abutment dimensions

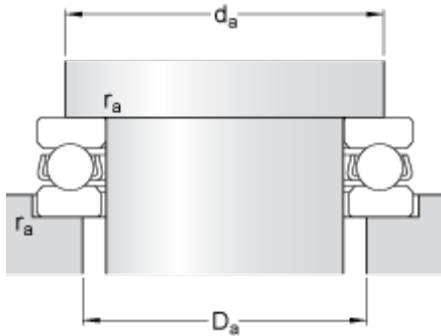

d <sub>a</sub>	min.	101	mm
D <sub>a</sub>	max.	94	mm
r <sub>a</sub>	max.	1	mm

## Calculation data

Basic dynamic load rating	C	76.1	kN
Basic static load rating	C	208	kN
Fatigue load limit	P <sub>u</sub>	7.65	kN
Reference speed		2400	r/min
Limiting speed		3400	r/min
Minimum load factor	A	0.22	

## Mass

Mass bearing (including seat washer where applicable)		0.91	kg
---	--	------	----