

51120

Dimensions

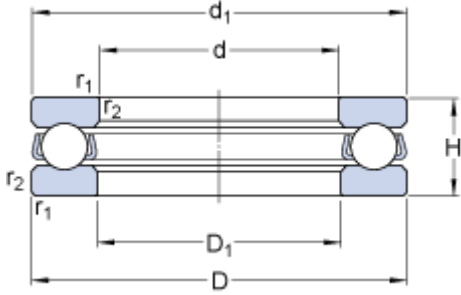

d		100	mm
D		135	mm
H		25	mm
d ₁	≈	135	mm
D ₁	≈	102	mm
r _{1,2}	min.	1	mm

Abutment dimensions

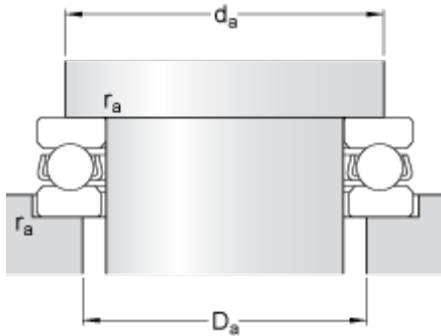

d _a	min.	121	mm
D _a	max.	114	mm
r _a	max.	1	mm

Calculation data

Basic dynamic load rating	C	80.6	kN
Basic static load rating	C	265	kN
Fatigue load limit	P _u	9.15	kN
Reference speed		2400	r/min
Limiting speed		3200	r/min
Minimum load factor	A	0.44	

Mass

Mass bearing (including seat washer where applicable)		0.97	kg
---	--	------	----