

51117

Dimensions

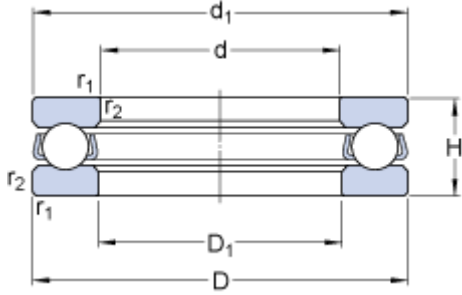

d		85	mm
D		110	mm
H		19	mm
d ₁	≈	110	mm
D ₁	≈	87	mm
r _{1,2}	min.	1	mm

Abutment dimensions

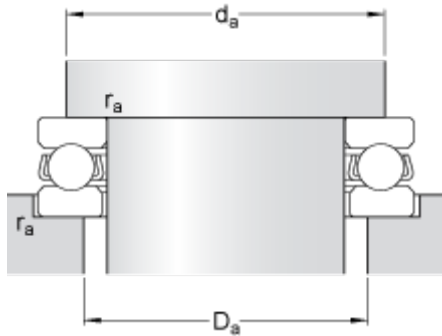

d _a	min.	100	mm
D _a	max.	95	mm
r _a	max.	1	mm

Calculation data

Basic dynamic load rating	C	44.9	kN
Basic static load rating	C	146	kN
Fatigue load limit	P _u	5.4	kN
Reference speed		3000	r/min
Limiting speed		4300	r/min
Minimum load factor	A	0.14	

Mass

Mass bearing (including seat washer where applicable)		0.44	kg
---	--	------	----