

51110

Dimensions

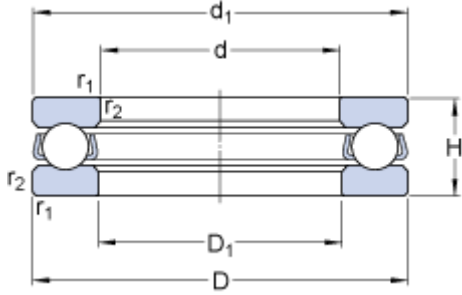

d	50	mm
D	70	mm
H	14	mm
d ₁	≈ 70	mm
D ₁	≈ 52	mm
r _{1,2}	min. 0.6	mm

Abutment dimensions

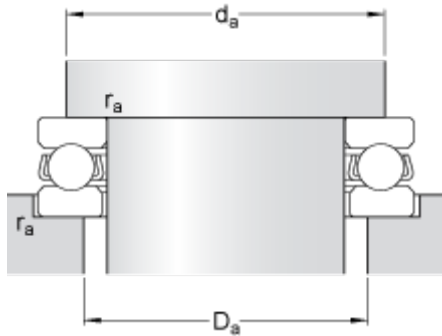

d _a	min. 62	mm
D _a	max. 58	mm
r _a	max. 0.6	mm

Calculation data

Basic dynamic load rating	C	27	kN
Basic static load rating	C	75	kN
Fatigue load limit	P _u	2.8	kN
Reference speed		4300	r/min
Limiting speed		6300	r/min
Minimum load factor	A	0.029	

Mass

Mass bearing (including seat washer where applicable)	0.16	kg
---	------	----