

51103

Dimensions

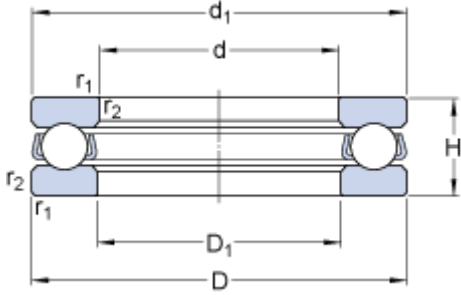

d		17	mm
D		30	mm
H		9	mm
d ₁	≈	30	mm
D ₁	≈	18	mm
r _{1,2}	min.	0.3	mm

Abutment dimensions

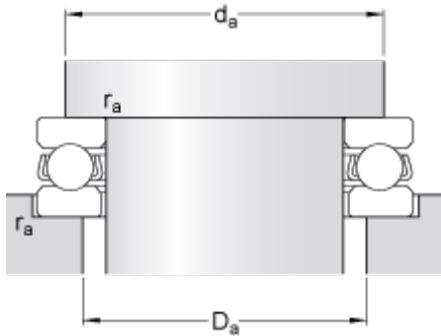

d _a	min.	25	mm
D _a	max.	22	mm
r _a	max.	0.3	mm

Calculation data

Basic dynamic load rating	C	11.4	kN
Basic static load rating	C	21.2	kN
Fatigue load limit	P _u	0.78	kN
Reference speed		8500	r/min
Limiting speed		12000	r/min
Minimum load factor	A	0.0023	

Mass

Mass bearing (including seat washer where applicable)		0.025	kg
---	--	-------	----