

51102

Dimensions

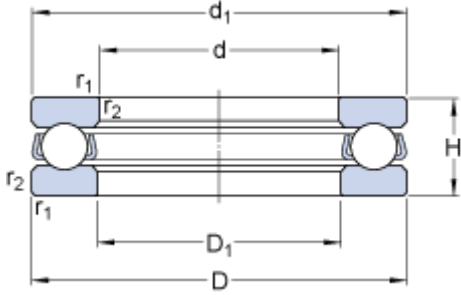

d		15	mm
D		28	mm
H		9	mm
d ₁	≈	28	mm
D ₁	≈	16	mm
r _{1,2}	min.	0.3	mm

Abutment dimensions

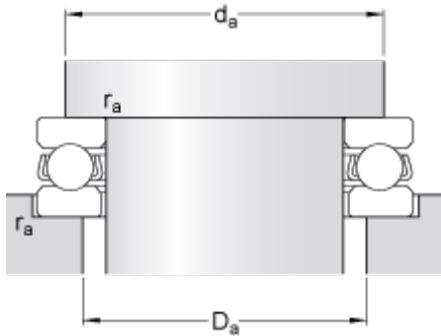

d _a	min.	23	mm
D _a	max.	20	mm
r _a	max.	0.3	mm

Calculation data

Basic dynamic load rating	C	10.6	kN
Basic static load rating	C	18.3	kN
Fatigue load limit	P _u	0.67	kN
Reference speed		8500	r/min
Limiting speed		12000	r/min
Minimum load factor	A	0.0017	

Mass

Mass bearing (including seat washer where applicable)		0.023	kg
-------------------------------------------------------	--	-------	----