

1220 K

Dimensions

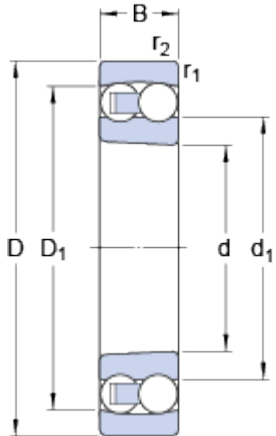

| | | | |
|------------------|------|-------|----|
| d | | 100 | mm |
| D | | 180 | mm |
| B | | 34 | mm |
| d ₁ | ≈ | 127 | mm |
| D ₁ | ≈ | 155.8 | mm |
| r _{1,2} | min. | 2.1 | mm |

Tapered bore, taper 1:12

Abutment dimensions

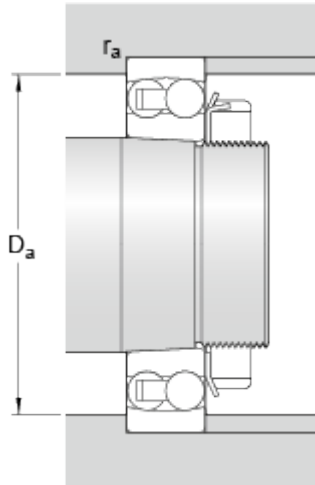

| | | | |
|----------------|------|-----|----|
| D _a | max. | 168 | mm |
| r _a | max. | 2 | mm |

Calculation data

| | | | |
|----------------------------------|----------------|------|-------|
| Basic dynamic load rating | C | 68.9 | kN |
| Basic static load rating | C | 30 | kN |
| Fatigue load limit | P _u | 1.29 | kN |
| Reference speed | | 7500 | r/min |
| Limiting speed | | 4800 | r/min |
| Permissible angular misalignment | α | 2.5 | ° |
| Calculation factor | k _r | 0.04 | |
| Calculation factor | e | 0.17 | |
| Calculation factor | Y | 4 | |
| Calculation factor | Y ₁ | 3.7 | |
| Calculation factor | Y ₂ | 5.7 | |

Mass

| | | | |
|--------------|--|-----|----|
| Mass bearing | | 3.6 | kg |
|--------------|--|-----|----|

