

# 120x150x15 CRSH1 R

## Dimensions

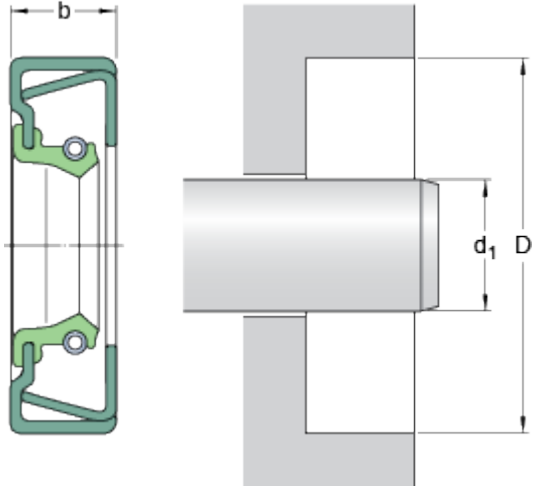

|       |     |    |
|-------|-----|----|
| $d_1$ | 120 | mm |
| D     | 150 | mm |
| b     | 15  | mm |

## Application and operating conditions

|                                     |      |      |       |
|-------------------------------------|------|------|-------|
| Pressure differential               | max. | 0.05 | MPa   |
| Operating temperature               | min. | -40  | °C    |
| Operating temperature               | max. | 100  | °C    |
| Operating temperature, short period | max. | 120  | °C    |
| Rotational speed                    | max. | 1592 | r/min |
| Shaft surface speed                 | max. | 10   | m/s   |